

AIC Newsletter

NUMBER 5

AUGUST 1990

Message from the President

In this, my first "Message from the President", I would like to pledge myself to work hard to justify the confidence you have expressed in electing me as your President. I hope that by the end of my term, in 1993, the AIC will be an even stronger and more vibrant organization than it is now.

I believe that one of the most effective ways to strengthen the organization as a whole is to strengthen the links between the members. As we are able to meet together in a full Congress only once every four years, with special-topic meetings in the intervening years, we must try to strengthen our links by an exchange of written news. There are two obvious ways to do this. One is through our own AIC Newsletter and the other is by exchanges of Newsletters between the national member organizations.

For the first, the new editor of the AIC Newsletter, Paul Green-Armytage, has worked hard to produce his first Newsletter, and has many good ideas for improvements in future issues. The Executive Committee will be discussing these ideas and others at its meeting in September 1990. We will welcome suggestions and comments from national members.

On the second means of communication, Allan Rodrigues has written to all the national member organizations, at my request, encouraging them to send copies of their Newsletters to other member countries with a view to republishing interesting articles and news. The Executive Committee will review the response to this suggestion in September and discuss the relation of such an exchange to the role of our own AIC Newsletter.

A vacancy has occurred on the Executive Committee because of the resignation of Dr.M.R.Pointer as Secretary/Treasurer. The replacement process is necessarily slow because we must give all members sufficient time to contribute to the selection procedure. However we have made good progress and hope to have a new Secretary/Treasurer in office before the end of 1990.

The Executive Committee has accepted an invitation from the Inter-Society Color Council to hold an AIC Interim Meeting in the USA in 1992. The meeting will be held on 21-24 June 1992 on the campus of Princeton University in Princeton, New Jersey. The topic will be "Computer Colorant Formulation". The full program of meetings for the next few years is thus:

1990 Instrumentation for Colour Measurement, 2-5 September 1990, Berlin, Germany (Federal Republic).

1991 Colour and Light, 26-28 June 1991, Sidney, Australia.

1992 Computer Colorant Formulation, 21-24 June 1992, Princeton, New Jersey, USA.

1993 Seventh AIC Congress, Colour 93, Budapest, Hungary.

EDITORIAL

One of the items on the agenda when the AIC executive meets in Berlin will be the future role of this newsletter. As the new editor I share President Alan Robertson's hope (expressed in his message) that the newsletter can contribute to the strengthening of links between members.

I plan to produce the newsletter once a year, probably in January. Apart from a report on the previous year's AIC meeting and information about future meetings I would like to include short reports from as many member countries as possible, highlighting the year's activities. I would also include reports from the three AIC study groups. In that this present issue does not contain all such items it is more of an interim newsletter.

We will be discussing the possibility of producing some or all of the newsletter in the three official languages of the AIC. This might present difficulties. It would probably be more expensive and take longer. After the executive meeting I will write to tell you what has been decided as editorial policy, but I am sure that contributions with translations will be especially welcome. Contributions in languages other than French, English and German, even if not accompanied by one or more translations, will also be welcome. I regret that this present issue of the newsletter is mainly in English; this is so that I can produce it reasonably quickly.

I will be very grateful for any comments and suggestions and look forward to receiving your contributions.

Paul Green-Armytage
Department of Design
Curtin University of Technology
P.O. Box U 1987
Perth 6001
Western Australia

TAROW INDOV RECEIVES JUDD-AIC AWARD

The Deane B. Judd-AIC Award was instituted in 1975 in honour of the memory of the outstanding colour scientist Deane B. Judd. It is awarded biennially by the Association Internationale de la Couleur (AIC) to recognize and honour persons who have performed work of outstanding merit in colour science. Previous recipients have been Miss Dorothy Nickerson, Professor Dr. William David Wright, Dr. Gunter Wyszecki, Professor Dr. Manfred Richter, Dr. David Lewis MacAdam, Professor Dorothea Jameson/Dr. Leo Hurvich, Professor Dr. Robert W.G. Hunt.

The 1989 Deane B. Judd-AIC Award was conferred on Professor Dr. Tarow Indow in recognition of his extensive contributions to the science and technology of colour, and in particular for his work on the method of multidimensional scaling and his work in which the global structure of the Munsell color space is examined by the method and its variations. His experiments were supported by the excellent technology of Japan to produce color chips and included tests of various methods of quantifying perceptual color differences of ranges within which color differences are meaningful for human eyes, of algorithms to define the configuration and the proof of some non-additivity involved in human assessment of color differences. All these are among the contributions noted here for recognition by the Association Internationale de la Couleur.

His professional career has extended over 40 years. He was Professor of Psychology in Keio University and has been, since 1977, Professor of Psychology at the University of California and also, since 1981, Adjunct Professor of Rensselaer Polytechnic Institute in Troy. He was President of the AIC from 1973 to 1977 and has served on the Executive Committee from 1969 to 1981. His contributions to the science of colour have earned him the admiration and gratitude of colleagues and associates throughout the international colour community. The Executive Committee of the Association Internationale de la Couleur is therefore pleased to honour Professor Dr. Tarow Indow with the 1989 Deane B. Judd-AIC Award.

The award consists of a gold medal with a portrait of Deane B. Judd on one side, and on the other side the inscription "To honour Tarow Indow 1989 for important work in colour science". The AIC presented the award to Professor Indow at its sixth Congress COLOR 89 in Buenos Aires on the 13th of March 1989.

Professor Dr. Heinz Terstiege
Past President

COLOR 89

The 6th Congress of the AIC, "Color 89", was held in Buenos Aires, Argentina on March 12 - 17, 1989.

The 176 delegates from 25 countries heard invited papers on "Colour in Architecture" by W. Spillmann, "Color Order Systems" by W.N. Hale, "Color formulation" by F.T. Simon, "Luminescence" by D. Gundlach, "Colour in Art and Architecture in Latin America" by J. Glusberg, "Color Education" by N. Howard, "Television and Colour Reproduction" by W.N. Sproson, "Colour in Foods" by R.D. Lozano, and "Colour in Signalling" by P.L. Walraven (read by C. Kleemans). There were also about 50 contributed oral papers and about 40 poster papers. In addition, open meetings were held of the three AIC Study Groups on Colour Order Systems, Colour Education and Environmental Colour Design.

During the meeting the 1989 Deane B. Judd AIC Award was presented to Dr. Tarow Indow of the University of California, USA, in recognition of his numerous contributions to colour science, particularly in studies of the multidimensional scaling of colour space.

At the closing session AIC President Heinz Terstiege announced the names of the new Executive Committee who will take office on 1st January 1990. They are A.R. Robertson (Canada), President; L. Ronchi (Italy), Vice-President; M.R. Pointer (Great Britain), Secretary-Treasurer; Paul Green-Armytage (Australia); A. Nemcsics (Hungary); L. Oberascher (Austria); and A.B. Rodrigues (USA).

Dr. Terstiege also announced that the next AIC Congress would be held in Budapest, Hungary in 1993 under the auspices of the Hungarian National Colour Committee and that an invitation had been received from the Color Science Association of Japan to hold the 1997 Congress in Japan. Interim meetings will be held on Instrumentation for Color Measurement in the first week of September 1990 in Berlin, Germany (Federal Republic) and on Colour and Light on June 26 - 28, 1991 in Sydney, Australia.

Alan Robertson

It is both a strength and a weakness of an AIC Congress that it attracts people from such a wide range of disciplines. Colour can bridge the gaps within and between the arts and sciences; it can also drive a wedge between them.

I have felt the suspicion and the lack of respect that different groups can hold for each other when they are brought together on these occasions. People go to an AIC Congress to learn the "state of the art", but reports on the latest findings from the various frontiers of research may only be understood by specialist minorities. This can be a source of resentment for those who specialise in different areas. I know that many delegates didn't attend or walked out of sessions that "didn't concern them". Nevertheless, I did sense a growing openness and a desire on the part of some groups to understand the concerns of others. I believe it should be a prime aim of the AIC to encourage this. Colour, after all, is the supreme interdisciplinary subject.

Speaking for myself, I became interested in colour as a designer and then found myself drawn into many different realms of enquiry, greatly assisted by my involvement with the AIC. This has been rewarding in itself but has also provided new insights and deepened my understanding of colour in my own field. "Color 89" did not disappoint me.

Paul Green-Armytage

INSTRUMENTATION FOR COLOUR MEASUREMENT

3rd - 5th September 1990

Bundesanstalt für Materialforschung und -prüfung (BAM)

BERLIN

The programme for the AIC Interim Symposium has been finalised and the city of Berlin has done the best thing by taking all its walls down to welcome visitors. Those who were at COLOR 81 will not recognize the city. With this in mind, and also because there is free admittance to any part of the city and the countryside, a boat tour has been arranged along the river Havel to Potsdam. The party will disembark there and visit "Sanssouci", the famous castle of Friedrich the Great. Dinner will be at Cecilienhof castle, where the Potsdam conference took place in 1945.

The invited papers will be:

"Colorimetry for Standard Conditions" - D. Gundlach, BAM Berlin

"Colorimetry of Metallic and Perlescent Colours" - A. Rodrigues, DuPont, Detroit

"Colorimetry of Retroreflective Materials" - N. Johnson - 3M, Minnesota

Enquiries should be addressed to:

Prof. Dr. H. Terstiege
AIC - Interim Symposium
DfWG c/o BAM
Unter den Eichen 87
D-1000 Berlin 45
Germany, Fed. Rep.

Tel: (030) 8104 5400
Fax: (030) 8112029

COLOUR AND LIGHT

25th - 28th June 1991

Powerhouse Museum of Applied Arts and Sciences

SYDNEY

Negotiations are underway to hold the opening ceremony for the 1991 AIC Symposium in the Sydney Opera House. This will be followed by lunch and a cruise on Sydney Harbour. Already more than 100 expressions of interest have been received from overseas with over 60 offers of papers. The papers committee, chaired by Dr Stephen Dain, are anticipating a very difficult task.

Before "Colour and Light", from 20th - 23rd June, the International Research Group on Colour Vision Deficiencies (IRGCVD) are having their symposium, also in Sydney. On 24th June there will be a joint IRGCVD and AIC meeting at the University of New South Wales on "Mechanisms of Colour Vision".

The second circular for "Colour and Light" will soon be ready for mailing. Enquiries should be addressed to:

COLOUR AND LIGHT 91
P.O. Box 495
Drummoyne
N.S.W. 2047
AUSTRALIA

COMPUTER COLORANT FORMULATION

21st - 24th June 1992

Princeton University

PRINCETON

The meeting will be a jointly sponsored AIC - ISCC meeting and symposium. The organising committee believe that by 1992 there will exist a great number of subjects within the framework of computer colour matching which will be worthy of a two day symposium. Among the subjects for lectures being considered are: Formulating metallics and pearlescents, Dealing with gloss differences between trial and calibration samples, Formulation and specification for visual display units, Use of visual display units to assist surface colour CCM, Use of visual display units for colour communications, Dealing with textures, and Ink on paper systems. The programme will end with a field trip to one of the many research facilities in the neighbourhood. Enquiries should be directed to:

Dr. Allan B.J. Rodrigues
E.I. DuPont de Nemours & Co.
945 Stephenson Highway
Troy
MI 48048
U.S.A.

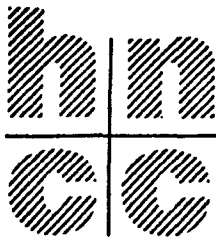

HUNGARIAN NATIONAL COLOUR COMMITTEE
COMITÉ NATIONAL HONGROIS DE LA COULEUR
UNGARISCHES NATIONALKOMITEE DER FARBEN
MAGYAR NEMZETI SZINBIZOTTSAG

HUNGARIAN ACADEMY OF SCIENCES, MAGYAR TU-
DOMÁNYOS AKADÉMIA SZINELMÉLETI ALBIZOTT-
SÁGA MINT AZ ASSOCIATION INTERNATIONALE
DE LA COULEUR MAGYAR NEMZETI BIZOTTSÁGA

Mr. Paul Green-Armitage
Dept. of Design
Curtin University
GPO Box U 1987
Perth 6001, Australia

Dear Sir,

In conformity with the decision made at its general assembly in Buenos Aires, the next Congress of AIC will be held in 1993 in Budapest. The Congress Organizing Committee has composed the preliminary program in annex. Please kindly write us your views, and suggestions concerning the tentative program, as well as names and addresses of experts and institutions in your country to send the first circular of the Congress to.

Let me drop some words on the Colour Museum. It is partly intended to present true to life relations between surface colours and chromatic and colour composition regularities, various colour systems, evolution of colour vision, development of pigments, colorations by different peoples, popular colour cultures. In addition to that, the establishment will include rooms for lectures and periodical exhibitions.

Because of actual financial difficulties in Hungary, Colour Museum is supposed to be realized by international cooperation. To that aim, on one hand, we are expecting to obtain the assistance from foundations, on the other hand, from important companies for them it would be meaningful to present their products, scientific achievements at a constant exhibition of scientific niveau easily accessible to Mid - and East-European specialists. You are asked to kindly suggest those possibly interested in your country. Let me mention that the Colour Museum building would be built on the right bank of the Danube, in an area between the site of the 1995 Vienna-Budapest World Exhibition, and campus of the Technical University of Budapest. I should be highly grateful to obtain your answer to June 20, 1990, much forwarding the efficacy of our organizatory work.

Sincerely yours:

Prof. Dr. A. Nemcsics
Chairman of the Organizing Committee

PRESIDENT: DR. ANTAL NEMCSICS PROF. TECHNICAL UNIVERSITY, BUDAPEST.
1111. BUDAPEST, MŰEGYETERM RKP. 3. HUNGARY.
T: 664-011 TELEX: 22 59M MŰEGY-H.

SECRETARY: MR. GÁBOR BARNA. HUNGARIAN SOCIETY FOR HUMAN SETTLEMENTS
1088. BUDAPEST, RÁKOCZI ÚT 7. HUNGARY. T: 143-046



The 7th Congress of the
ASSOCIATION INTERNATIONALE DE LA COULEUR
INTERNATIONAL COLOUR ASSOCIATION
INTERNATIONALE VEREINIGUNG FÜR DIE FARBE

C O L O U R 93

BUDAPEST
HUNGARY

Sketch of the Congress program:

Subject groups:

1. Colour vision and colour appearance
Theories of colour vision, colour adaptation, colour contrast, irradiation, colour constance, colour memory
2. Colorimetry and colour standardization
Colorimeter systems, colour differences, colour metamery, formulae prone to standardization, fluorescence, colorimeters
3. Colour systematization
Colour system theories, psychometric scales, study of historical and actual colour systems, transformations between colour systems, printed and electronic colour collections
4. Colour dynamic research
Colour preference, colour association, colour biology, colour psychology, colour-space-mass-surface-form, theories of colour harmony, colour and function, colour and function, colour and illumination, ergonomics
5. Industrial colour applications
Colour reproduction, colour formulation, colour printing, colour TV
6. Colour design
Colour design for establishments of different functions, monuments, townscape complexes. Colour in fine arts. Colour design methods. Computerized colour design
7. Education in chromatics
Primary, secondary and higher education in chromatics, postgraduate education, tools for chromatic education

C o n f e r e n c e s :

1. Preferential conferences:
40 min conferences each of internationally outstanding experts of the seven subject groups, on the actual situation of the scope.
2. Verbal conference
90 conferences in three parallel sections, at 20 min each.
3. Conferences by posters
Exhibition of 200 sq.m of posters, 3 x 50 min for verbal comments on, and discussion of, the posters
4. Discussion forums
Discussion of statements made in the scope, and of some specially designed problems in 7 x 50 min discussion meetings

Exhibitions

Colorimetric instruments
Computer programs for colour transformation and colour design
Environment colour designs
Chromatic education
Fine arts exhibitions

COLOUR MUSEUM

True to life presentation of surface to bright colour relations, chromatic and colour composition regularities. Different colour systems. Development of colour vision. Popular coloration, popular colour culture.

Related international organizations:

CIE, Lux Europa, TC1 and TC2
Organizer: Janos Schanda
Study Group on Colour Order System
Organizer: Nick Hale
Study Group on Colour Education
Organizer: Christine Burton
Study Group on Colour Dynamics
Organizer: Leonhard Oberascher
International Academy of Colorsciences
Organizer: Henry Wohlfarth
International Association of Colour Consultants
Organizer: Frank Mahnke
Association of Ecological Design
Organizer: Istvan Bartha

Planned time of the Congress:

third or fourth week of June 1993

Planned site of the Congress:

Technical University of Budapest:
Muegyetem rkp.3.
Budapest
H-1521

EXHIBITION HALLS

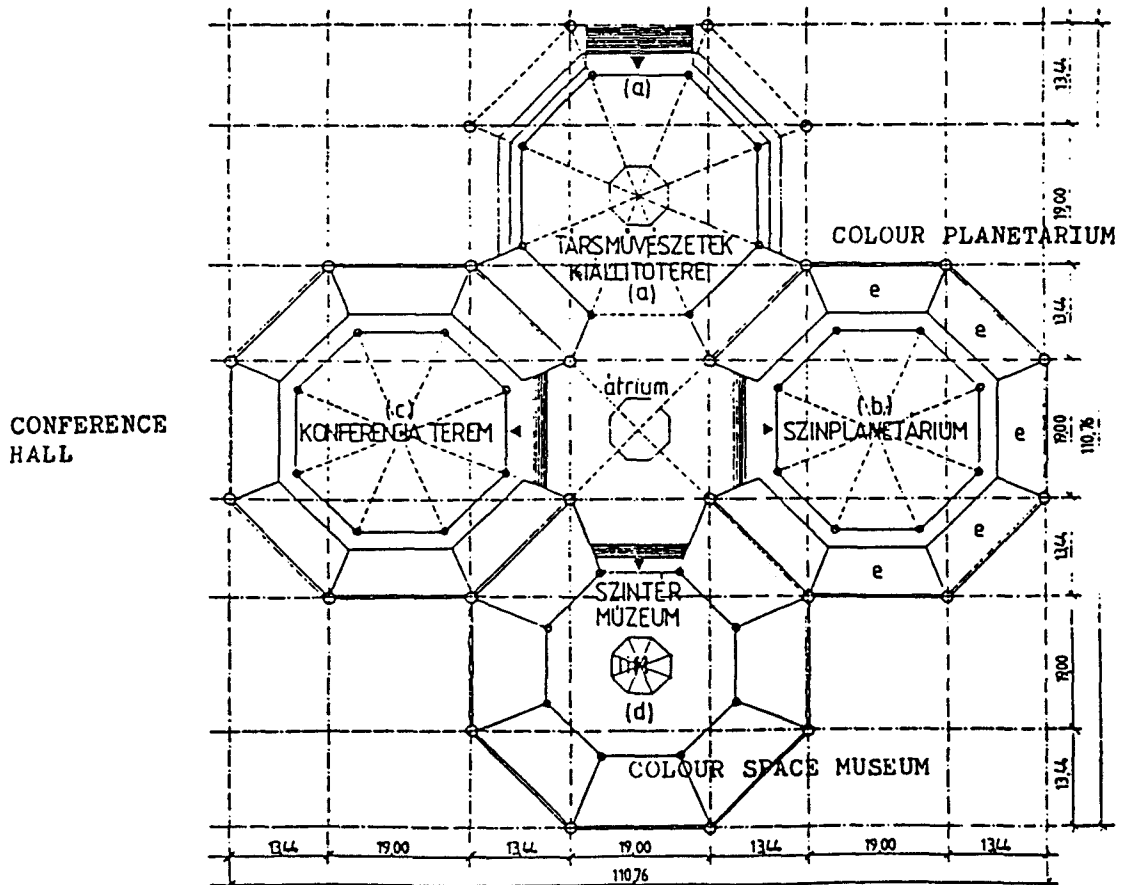

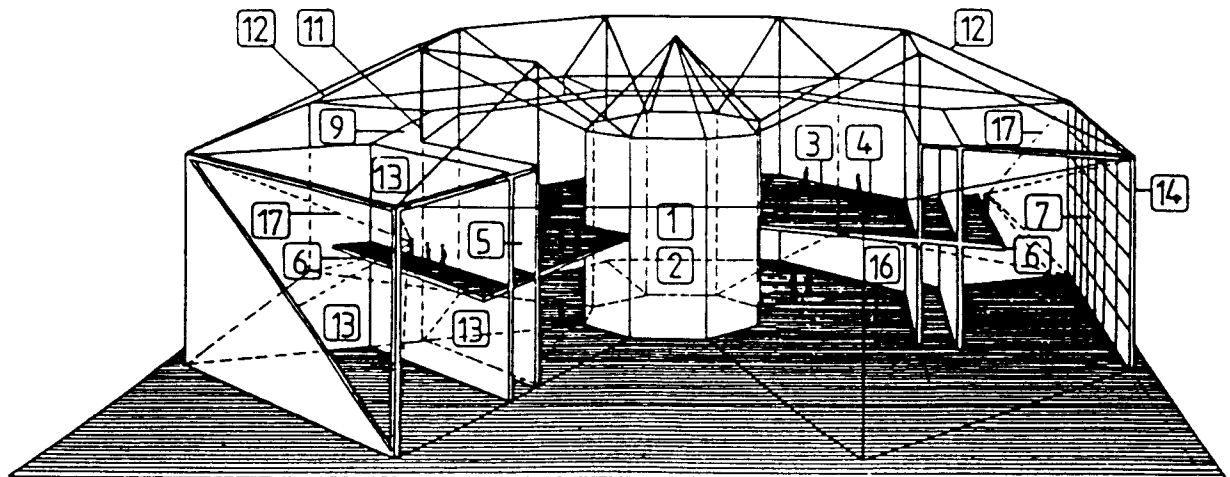
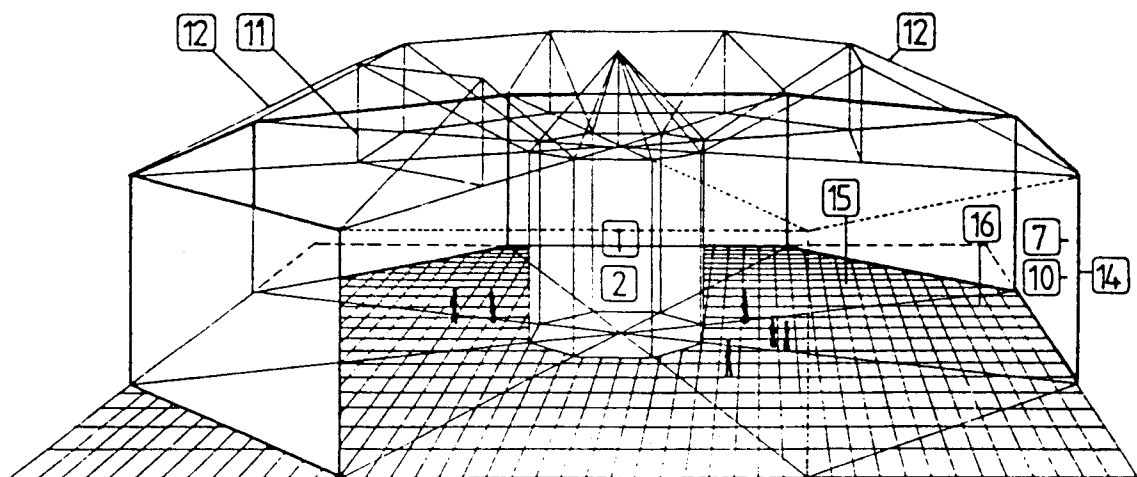
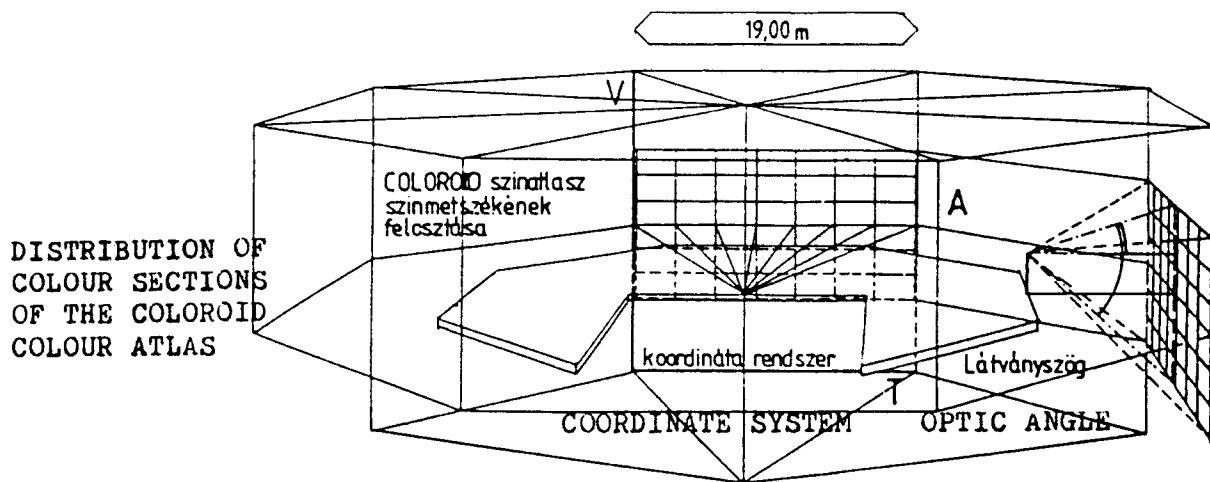

STEVEN SHEVELL RECEIVES FIRST BARTLESON AWARD

To recognize work of international significance in the field of colour, a C. James Bartleson Award has been established. Funds for a Trust, to be known as "The C. James Bartleson Award Trust", have been provided by Mrs C.J. Bartleson. The award is administered by five Trustees; two of these are appointed by the Department of Optometry and Visual Science of The City University, London, England, at which Dr Bartleson received his Doctorate of Philosophy; two are appointed by The Colour Group (Great Britain), of which he was a Committee Member and a Newton Lecturer and Medallist; and one is appointed by Mrs C.J. Bartleson.

The award consists of a monetary prize of one thousand pounds sterling and a medal. The medal shows a portrait of Dr Bartleson on one side, the other side being inscribed with the words "Presented to (recipient's name) for significant work in Colour Science (year of presentation)". The award will normally be presented after a special lecture delivered by the recipient to mark the occasion. It is expected that awards will be made at approximately two yearly intervals, and that a total of about five awards will be made.

The award has been established to recognize significant work in colour science, and to encourage excellence in this field. Recipients of the award will be selected by the Trustees. In selecting the recipients, the Trustees will give priority to persons who are young, and who have shown outstanding ability to produce well-written papers.

The first award was made at the C. James Bartleson Symposium on Colour Appearance on 4th October 1989. The symposium opened with tributes to Dr Bartleson's life and scientific career from Robert Hunt, Margaret Halstead and Alan Robertson. Robert Hunt presented a fascinating review of Dr Bartleson's life and work, copiously illustrated with slides and reminiscences. Margaret Halstead and Alan Robertson then spoke, both concentrating on his work for the AIC and CIE.

Following these tributes, the first presentation of the Bartleson Award was made to Dr Steven K. Shevell by Mrs C.J. Bartleson for Dr Shevell's outstanding contribution to the field of colour appearance. A small presentation was also made to Mrs Bartleson.

Dr Shevell then gave his prize lecture on "Colour Contrast and Colour Context". In this paper he reviewed his research into the fact that a light that is part of a complex visual scene may have a hue that is difficult to specify in advance, and that appearance depends on both contrast (the effect of adjacent colours) and context (the effect of more remote, non-adjacent colours).



15, passage de la Main d'Or 75011 PARIS - Tél : (01) 48.05.31.86

Centre Français de la Couleur (C.F.C.) has been very active during the last two years. First, in liaison with its reorganization, the official and permanent head office address has been moved from the Museum d'Histoire Naturelle in Paris, to join the well-know Comite National Français de l'Eclairage and the Association Française de l'Eclairage at 52, Boulevard Malesherbes in Paris (75008), but the business address is remaning unchanged :

Centre Français de la Couleur
15, passage de la Main d'Or
75011 PARIS

Dr Robert Sève was reelected as the CFC President for a new term in February 1988.

During this two years period, C.F.C. has organized a number of meetings by itself or in cooperation with other organizations. Among the most interesting meetings for scientific readers, we can mention here :

- a half-day meeting about colour and communication in packaging (december 1988) with the participation of invited foreign speakers from USA, Japan, Italy.
- a meeting on colour and ethnology (june 1988) in relation with an exhibition at the Musée des Arts et Traditions Populaires in Paris devoted to traditional workshops in relation with colour at the beginning of this century (from may to july 1988)

C.F.C. has also been actively involved for conferences, talks in many places in France and for papers published in technical reviews. Among them : Colour and communication, Colour and marketing, colour and design in movie theater, Colour education, Colour measurement in industry, Colour science, Colour of Champagne wines, Colour and cartoons...

C.F.C. published an important document (july 1988), a classified colour bibliography (approximately 400 references) giving publications made by french authors from 1983 to 1987 and related to all aspects of colour. (bibliographie de la couleur en France).

C.F.C. is mantaining an increasing activity about colour education mainly for industry as seminars of four days intended for technicians and scientists. It is also participating in similar activities in France done by other organizations. Parallel to this activity C.F.C. is developing a research about the content of such seminars and about the best pedagogy in the fiel of colour education with a scientific background.

Paris, February 25, 1989

Färginstitutet

SKANDINAVISKA FÄRGINSTITUTET AB • SCANDINAVIAN COLOUR INSTITUTE

Visitors	Mail	Phone	Teletex
Igeldammsgatan 30	PoBox 49022	Nat 08-54 20 80	8106238 SCANDCOLOR
	S-100 28 Stockholm Sweden	Int +46 8 54 20 80	Telefax 08-50 56 67

Stockholm 1989-11-09

Our ref. TH/
L:8909128.hs

National Reserach Council of Canada
Attn. Dr A R Robertson
Division of Physics
Ottawa, Ontario, Canada
K1A 0R6
Canada

Dear Dr Robertson,

We would like to contribute to the "AIC Newsletter".

The Swedish colour researcher Anders Hård has recently obtained honorary doctor of science at the Chalmers University of Technology. The award was received from the hands of his majesty the King of Sweden for the work within the field of colour.

Anders Hård has been responsible for the Swedish colour reserach carried out at the Swedish Colour Centre Foundation for more than 20 years. The work resulted in the NCS - Natural Color System familiar to all colour' reserachers. The last five years he has been working on establishing a colour research department at the architectual department at the Chalmers University of Technology of Gothenburg.

Yours sincerely
SCANDINAVIAN COLOUR INSTITUTE AB



Gunnar Holmar

NEDERLANDSE VERENIGING VOOR KLEURENSTUDIE

Our Colour Council invited two speakers in November 1988 for the subjects: "Colour from the Oceans" presented by Dr R. Laane and "Colour from the Sky" presented by Dr G. Kunz. The subjects belong to the "Research of Oceanography from Space".

Two big meetings were held in 1989. In April, at the van Gogh Museum in Amsterdam, the main subject was "Our Skin, our Expanded Skin and their Colour - Cosmetics and Fashion". In November the subject was "Colour in Architecture". The speakers were Professor Werner Spillmann, Director of the Colour Course Centre in Winterthur, Switzerland, and Dr Alberts, architect of the new NMG Bank. This bank has been built following new colour principles.

Ir. C.H. Kleemans

THE COLOUR SOCIETY OF AUSTRALIA

"Colour Renaissance" was the theme for the second biennial conference of the Society which took place in Melbourne in October 1989. The event was a great success. We were very pleased to welcome two distinguished speakers from overseas: Keith McLaren (Great Britain) spoke on "The CIE Method of Colour Measurement" and "Visual and Instrumental Colour Control". Gary Field (USA) spoke on "The Art and Science of Colour Correction".

The conference excursion up the Yarra river for a picnic lunch and visit to the historic Villa Alba had been arranged for the day before the conference. This was contrary to the usual practice of a mid conference excursion and was so successful that the pattern has been adopted for "Colour and Light" in Sydney next year. Participants were able to get to know each other before the conference proper began. This meant that the time between sessions was used to the full for discussion and there was a much greater sense of involvement than usual on such occasions.

The Society has grown dramatically in its short life. We now have over 200 members with divisions in New South Wales, Victoria, Western Australia and the Australian Capital Territory. There was a strong presence from South Australia at the conference and we expect to see a division formed there soon.

We are looking forward to welcoming the World to Sydney in 1991.

Paul Green-Armytage

LVMH
MOËT HENNESSY, LOUIS VUITTON

Paris, le 16 Mai 1990

Chère Madame, Cher Monsieur,

Le Prix Scientifique L.V.M.H. "Science pour l'Art" a pour vocation de récompenser les initiatives scientifiques pour leurs prolongements dans le domaine de la création esthétique.

Sur le thème "Application de matière sur une surface, les trois jurys de Paris, Tokyo et New York ont, cette année, décidé d'attribuer le Prix à deux personnalités scientifiques dont les travaux ont largement contribué à resserrer les liens entre Science et Art : Hans KUHN, premier prix scientifique et Werner OSTERTAG, premier prix de l'innovation.

La cérémonie officielle de remise des prix aura lieu traditionnellement à La Conciergerie de Paris, le 12 Juin 1990, sous la présidence de Ricardo-Diaz HOCHLEITNER, Président du Club de Rome.

L'avant-propos de Jacques MANDELBROJT, Professeur de physique à l'Université d'Aix-Marseille, sera suivi de la présentation des lauréats par Pierre-Gilles DE GENNES, Professeur au Collège de France et lauréat en 1989.

Après la remise des prix par Bernard ARNAULT, Président de L.V.M.H., les lauréats recevront l'hommage de grands artistes internationaux tels Madame Setsuko KLOSSOWSKA DE ROLA, peintre suisse d'origine japonaise, Madame Alev SIESBYE, céramiste turque et Itchiku KUBOTA, grand maître du "Tsuji-gahana" (art du kimono).

Une exposition des oeuvres de ces artistes sera organisée dans la grande salle SAINT-LOUIS; exposition qui sera suivie d'un cocktail.

En souhaitant vous compter parmi nos invités, je vous prie d'agréer, Chère Madame, Cher Monsieur, l'expression de mes sentiments les meilleurs.

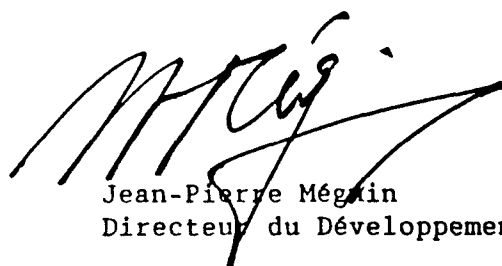

Jean-Pierre Mégain
Directeur du Développement

Moët-Hennessy

U.S. CORPORATION

May 16, 1990

Mr. Paul Green-Armitage
Dept. of Design
Curtin University
GPO Box U 1987
Perth 6001
Australia

Dear Mr. Green-Armitage,

We are pleased to announce that the 1990 LVMH Science for Art Prize is awarded to Hans KUHN for the Scientific Prize and to Werner OSTERTAG for the Innovation Prize. A special Artistic Mention is also awarded to Peter STRUYCKEN. Please find here attached more information about the prize winners.

The Prize ceremony will be held in La Conciergerie, in Paris on June 12, 1990.

We would be pleased if you could announce these results to the members of the AIC through your newsletter and to your affiliated national societies, as suggested by Dr. Allan Rodrigues.

Please do not hesitate to contact me if you have any question concerning this Prize.

We thank you for your interest in the Science for Art Prize and we look forward to hearing from you.

Yours sincerely,

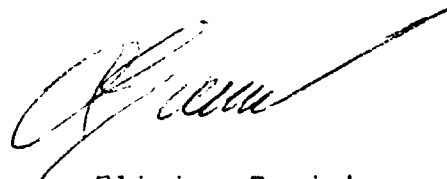

Olivier Goniak
Scientific Attache

enclosure

PRIX LVMH SCIENCE POUR L'ART 1990
PREMIER PRIX SCIENTIFIQUE

HANS KUHN
ASSEMBLAGES MOLECULAIRES,
COULEURS ET MATIERE VIVANTE

Né à Berne en 1919, Hans Kuhn étudie la chimie à l'Ecole Polytechnique de Zürich et à l'Université de Bâle, puis poursuit ses recherches avec Linus Pauling et Werner Kuhn au Danemark. Professeur à l'Université de Marburg en 1953, il fut encore récemment Directeur du Département de Chimie Biophysique au Max Planck Institut de Göttingen.

Il est nommé pour ses travaux théoriques qui couvrent un vaste domaine dans l'étude des phénomènes de surface, depuis les propriétés des couches monomoléculaires jusqu'aux interactions énergétiques d'arrangements moléculaires complexes qui sont peut-être à l'origine de la transition matière inerte- matière vivante. Ses travaux ont permis des progrès considérables dans la technologie des dépôts de films organiques et dans la compréhension des interactions physicochimiques complexes liant couleurs et structures moléculaires.

PRIX LVMH SCIENCE POUR L'ART 1990
PREMIER PRIX INNOVATION

WERNER OSTERTAG
PALETTE COLOREE DES OXYDES DE FER
SUR L'ECLAT DE L'ALUMINIUM

Né en 1935 en Allemagne, le Docteur Werner Ostertag étudie les composés intercalaires des terres rares à l'Université de Tübingen puis au sein de Corning Glass aux Etats-Unis. Après avoir rejoint en 1970 le centre de recherches de BASF à Ludwigshafen, il se consacre à l'étude des pigments minéraux.

Il est nommé pour le développement et la fabrication d'un nouveau type de pigments interférentiels constitués de particules d'aluminium revêtues d'une mince couche d'oxyde de fer. Ces pigments non toxiques, très stables et dotés de propriétés esthétiques et optiques tout à fait remarquables sont du plus haut intérêt pour les industries liées aux métiers de la décoration.

PRIX LVMH SCIENCE POUR L'ART 1990
APPLICATION DE MATIERE SUR UNE SURFACE

Une Mention Artistique spéciale est décernée à l'artiste hollandais Peter STRUYCKEN pour sa présentation intitulée "Couleur, Espace et Changement". Son analyse de la distribution de motifs colorés et lumineux dans l'espace et le temps et sa maîtrise de la dimension couleur-espace permettent la création d'effets artistiques appliqués à l'art graphique, à la photographie et à l'architecture.

1990 LVMH SCIENCE FOR ART PRIZE
SCIENTIFIC PRIZE

HANS KUHN
MOLECULAR ASSEMBLY,
COLOR AND LIVING MATTER

Dr. Hans Kuhn was born in Bern (Switzerland) in 1919. He studied chemistry in Switzerland at the Ecole Polytechnique of Zurich and at the University of Basel and in Denmark with Linus Pauling and Werner Kuhn. Until recently, he has been Professor at the University of Marburg and Director of the Department of Biophysical Chemistry at the Max-Planck Institute in Gottingen, West Germany.

The Scientific Prize is awarded to Hans Kuhn for his wide-ranging theoretical studies, from the properties of monomolecular layers to the energy interactions in complex molecules, interactions which may constitute the transition from inert to living matter. His work has led to important advances in the technology of organic film deposits and has led to a profound understanding of the complex physico-chemical interactions linking color to molecular structure.

1990 LVMH SCIENCE FOR ART PRIZE
INNOVATION PRIZE

WERNER OSTERTAG
COLORED PALETTE OF IRON OXIDE
UNDER THE SPELL OF ALUMINIUM

Dr. Werner Ostertag was born in 1935. His early studies in Germany at the University of Tübingen and in the United States with Corning Glass Company were concerned with the composition of the intercalated layers of rare earths. Since his return to BASF in Ludwigshafen in 1970, he has been working on mineral pigments.

The Innovation Prize is awarded to Werner Ostertag for the development and manufacture of a new type of interference pigment consisting of aluminium particles covered with a thin layer of iron oxide. These stable and non-toxic pigments have remarkable aesthetic and optical properties, making them of the greatest interest to industries related to the decorative arts.

1990 LVMH SCIENCE FOR ART PRIZE
APPLICATION OF MATTER ON A SURFACE

A special Artistic Mention is given to the Dutch artist Peter STRUYCKEN for his work entitled "Colour, Space and Change". His analysis of pattern distribution of color and light in space and time and his control of the color-space dimension has led to the creation of artistic designs and applications for graphic art, film and architecture.

Member Organizations and their Representatives of the AIC:

Grupo Argentino del Color
Lic. R. D. Lozano
INTI, Division Optica
Cas. de Correo 157
1650 S. Maretin B.A.
Argentina

Colour Society of Australia
Dr. B. Powell
P. O. Box E 184
St. James N.S.W. 2000
Australia

Arbeitskreis Farbe der OVE-OIAV
Dr. F. Rotter
Fachgruppe Mesztechnik
Arltgasse 35
A-1163 Wien
Austria

Centre d'Information de la Couleur Belgique
Mme. J. Verschuere van Helden
S.A. Levis N.V.
171 Leuvensesteenweg
B-1800 Vilvoorde
Belgium

Canadian Society for Color
Dr. A. R. Robertson
National Research Council
Division of Physics
Ottawa K1A OR6
Canada

Color Association of China
Prof. Shu Yuexin
Shandong Textile Engineering
College
Dept. of Color Sci.
Qingdao
PR China

Centre Francais de la Couleur
Dr. Robert Sève
Acora 15
Passage de la Main d'or
75011
Paris, France

Deutscher Verband Farbe
Dr. G. Geutler
Institut für Lichttechnik
TU Berlin
Einsteinufer 19
D-1000 Berlin 10
Germany

The Colour Group (Great Britain)
Dr. M. R. Pointer
Kodak Ltd., Res. Div.
Headstone Drive
Harrow Middlesex HA14TY
Great Britain

Hungarian National Colour Committee
Dr. A. Nemcsisc
Technical University of Budapest
Müegyetem rkp. 3
H-1111 Budapest
Hungary

Colour Group of India
Dr. N. S. Gangakhedkar
Compute Spectra Pvt Ltd
1, Manisha, Malviya Road
Vile Parle (E), Bombay - 400 057
India

Assoziazione Ottica Italiana
Prof. L. R. Ronchi
Istituto Nazionale di Ottica
6 Largo Fermi
I-50125 Firenze
Italy

Color Science Association of Japan
A. Kodama
Japan Color Research Institute
1-19 Nishiazabu 3-Ch
Minato-Ku, Tokyo 106
Japan

Nederlandse Vereniging voor Kleurenstudie
Ir. C. H. Kleemans
Zuidlaan 22
NL-211 GC Aerdenhout
Netherlands

Norsk Farveforum
U. Willumsen
P. O. Box 1714 Hystad
N-3200 Sandefjord
Norway

Polish Committee for Standardization
Prof. Dr. Sobczak
ul. Elektralna 2
PL-139 Warszawa
Poland

South African Colour Science Association
Dr. C. J. Kok
Division of Production Technology
Electromagnetic & Particle Metrology
Pretoria 0001
South Africa

Comite Español del Color
Dr. E. Sauras
Instituto de Optica
Serrano 121 - Madrid 6
Spain

Svenska Färggruppen
Mr. Thomas Hård
Swedish Colour Centre Foundation
P. O. Box 49022
S-10028 Stockholm
Sweden

Schweiz. Lichttechnische Gesellschaft
Dr. Charles Giroud
Postgasse 17
CH-3011 Bern
Switzerland

Inter-Society Color Council
Mr. H. S. Fairman
Armorguard Products
P. O. Box 215
Andover, NJ 07821
U.S.A.

Associate Members:

Int. Res. Gr. on Colour Vision Deficiencies

No representative appointed since the death of Dr. Verriest.

Observers of the AIC:

G. Marconi
Grafica Editora Colon, S.A.
Apartado 6-2797
Estafetat El Dorado
Panama

St. Tang Beng Chye
Singapore Institute of Standards
& Industrial Research
1 Science Park Drive
Singapore 0511

Prof. B. B. Togrul
Institute of Experimental
Psychology
K.P. 30, Kadikoy
Istanbul
Turkey

Prof. Dr. S. Jeler
Universität Maribor
Smetanova Ul. 17
6200 Maribor
Yugoslavia

Mrs. M. Terkildsen
Dansk Farveinstitut
Nygardterasser. 277E
DK-3520 Farum
Denmark

Mrs. T. Tosca
Thessaloniki Polytechnical
School
Dept. of Architecture
7 Rue Greg. Palama
54622 Thessaloniki
Greece

Mrs. J. Ruttenberg
Tambour Paints Ltd.
Hagatstreet 14
52603 Ramat-Gan
Israel

1990-1993 Executive Committee of AIC:

President:

Dr. A. R. Robertson
National Research Council
Division of Physics
Ottawa K1A OR6
Canada

Vice-President:

Prof. L. R. Ronchi
Istituto Nazionale di Ottica
6 Largo Fermi
I-50125 Firenze
Italy

Secretary/Treasurer:

Members:

Mr. Paul Green-Armitage
Dept. of Design
Curtin University
GPO Box U 1987
Perth 6001
Australia

Dr. A. Nemcsisc
Technical University of Budapest
Müegyetem rkp. 3
H-1111 Budapest
Hungary

Dr. Leonard Oberascher
University of Salzburg
Inst. f. Psychologie
Hellbrunnenstr. 34
A-5020 Salzburg
Austria

Dr. Allan B. J. Rodrigues
E. I. Du Pont de Nemours & Company
P. O. Box 2802
Troy, Michigan 48007-2802
U.S.A.